

Universal Mustang II IFS Kit

Measure twice, weld once!

1. Determine Correct Axle Center Line & Ride Height:

A. Begin your installation by locating the axle centerline of your vehicle. If you have the original suspension in place, then just transfer the centerline of the spindles with a vertical line onto the side of the frame rails. If the original suspension is gone, then the best way to do this is to stand a fender in place on the frame and stand the front wheel and tire in place in the fender. Now, slide a broom handle or tube straight through the wheel center. Mark a vertical line at the location where it contacts the frame. This will then place the spindle centerline in the center of the fender opening, right where you want it. Now that you know where the front-to-back spindle center line is, measure the width of the frame at that point. The maximum standard frame width that will fit between the springs is about 30". If your frame is wider than that, it will need to be C-notched for the springs. If you still have the original suspension on the frame, it must now be removed.

B. Now you must determine the ride height of the front suspension, and actually of the entire car, as the frame must also be set at the correct rake that you intend the finished car to sit. Adjust the height of the frame, or the entire car, to this height, and then support the frame on jack stands with shims at this height. Now check the height of the spindle, again using your set-up wheel, compared to the height of the frame rail, at the axle centerline. Mark the actual spindle centerline height on the side of the frame rail (You may want to subtract 1/4" from the centerline location for flattening of the tires under pressure). If it comes through the wheel below the frame rail, then temporarily tape a piece of cardboard to the side of the rail to mark the centerline on. The bottom of the frame should be no lower than one inch below the spindle and the top not more than four inches above the spindle. As you see, you can adjust the ride height of your car within this range, if your frame is smaller than these dimensions (See **Figure 1** below). You can also adjust the position of the crossmember, and the frame, with 2" Dropped Mustang II Spindles, if the frame does not fall within this range. Note that if the frame is more than 1/2" below the spindle, it will need to be C-notched for the rack boots, if you do not use dropped spindles. Also note that if you have a thicker frame, just slice a 12" long section off and box in the top of the frame for the spring tower and upper control arm clearance. The depth of this slice will be determined in a later step.

2. Trimming & Mounting Crossmember

A. The inside dimension of your frame rails will determine where you make the vertical cuts on your new crossmember so that it slides up inside the frame rails. For example if your frame measures 29" inside to inside, then your vertical cuts on your crossmember should be 29" to match. You may want to mark your crossmember's side-to-side centerpoint, then measure half the distance of your inside frame rail distance (14 1/2" in our example) to determine where to make your vertical crossmember cuts on the driver and passenger sides. (See **Figure 2a** below)

B. The horizontal cuts are determined as follows: The lower control arm pivot bolts are 3-1/2" below the spindle centerline on the standard Mustang geometry. Measure down (or up) from your spindle centerline mark to the bottom of your frame rail. Subtract (or add) your dimension from 3-1/2" and the difference will be the dimension from the control arm inner bolts to the horizontal cuts on the crossmember. You will need to do this twice, 1-3/4" forward and rearward of the spindle centerline, as this is where the crossmember will actually contact the frame. Also keep in mind that your frame is tapered and sitting on an angle, so the front and back cuts are almost never the same. Also remember that the crossmember should be level, both side to side and front to back.

C. Transfer dimensions to crossmember. Please note the rack mounts are located on the front of crossmember. It is important to double check all measurements and cut the crossmember. In order to insure a proper fit you need to cut off slightly less than your measured for tight fit. At this point in time the crossmember is centered on spindle centerline.

D. When crossmember is in place, check it for level, then tack weld in place.

E. Verify the crossmember is as high in the frame as desired. To do this, temporarily assemble the lower control arms and spindles onto crossmember.

F. Temporary clamp a 2x4 under crossmember with a couple of shims to support the control arms level and stand spindles up on ball joints.

G. Verify ride height. If your ride height is not as desired, then remove crossmember and remove or add material as need then retack in place. Please check upper control arm mounts and confirm they do not need adjustments for positioning of the crossmember.

3. Upper Control Arm Mounts

The spring towers are positioned 35" to 36" apart measured from center of the shock cup holes, and are placed 1-3/4" forward of the crossmember's front face.

To determine the spring tower's horizontal cut locations, see **figure 1** below. Use the center of the lower control arm bolt hole in the crossmember as the lower reference point, and the top of the spring tower as the upper reference point. Hold the spring tower against the outside of the frame rail so that the front edge of the spring tower is 1 3/4" forward of the front face of the crossmember. Now adjust spring tower height so that its front top edge is 9 1/4" from the center of the lower control arm bolt hole, and the rear top edge of the spring tower is 8 7/8" from the center of the lower control arm bolt hole. When your measurements are certain, use the top side of the frame to mark your horizontal cut marks on the spring towers. (Note if you want to adjust your ride height, you can move the crossmember up or down, but you must move the spring towers an equal amount so that the 9 1/4" and 8 7/8" measurements are unchanged.)

C. Confirm correct installation by holding the spring towers on top of frame and at 35" to 36" spread dimension. Then make sure that they are aligned. You can do this by confirming the slots for upper control arms are in line with each other from spring tower to spring tower.

D. Mark the spring towers vertically from outsides of the frame rails. Make sure that the upper spring plates (surface with two slots) are flat to each other from one spring tower to another spring tower across frame. In addition the spring mount cups should be tilted slightly up in the front for anti-dive. The spring tower should be 3/8" to 1/2" higher in front than in back.

E. Start cutting the spring towers to fit. It may take a couple of cuts and some fitting to make a tight fitment. In the event your measurements show the back of the spring towers need to be cut so it is less than 1", you will need to either raise the entire crossmember and spring towers and reconsider selected ride height, or remove part of top of frame and box it in. Please note the upper control arm rear needs a minimum of 1" height for clearance..

F. Tack weld spring towers in place.

G. To insure correct installation and placement double check measurements again.

I. Test fit the steering rack by installing it to the crossmember. Installation is correct if the steering rack clears the frame by 1/4" or more. In the event you do not have 1/4" clearance you will need to C - notch the frame for the rack.

J. At this point, assemble one side (lower control arm, upper control arm, and spindle). Make sure the spindle is plumb vertically, and check to see that the upper control arm bolts are roughly centered in the spring tower slots. If they are, this will give you plenty of caster/camber adjustment. If not, move the spring tower in or out accordingly. When everything is in proper position, weld the crossmember to the frame.

4. Assemble and Align

A. Install all the suspension components to the crossmember for the front suspension.

B. Align your vehicle with the following specifications

-Caster :: 1 degree positive

-Camber :: 1/2 degree positive

-Toe-in :: 1/8"

C. Recheck your welds, bolt torques, caster, camber, and toe-in after 100 to 200 miles.

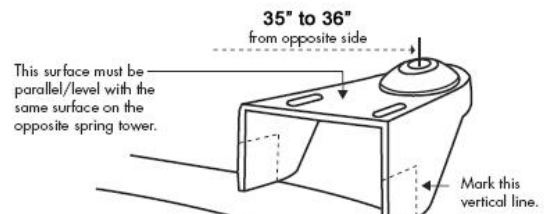
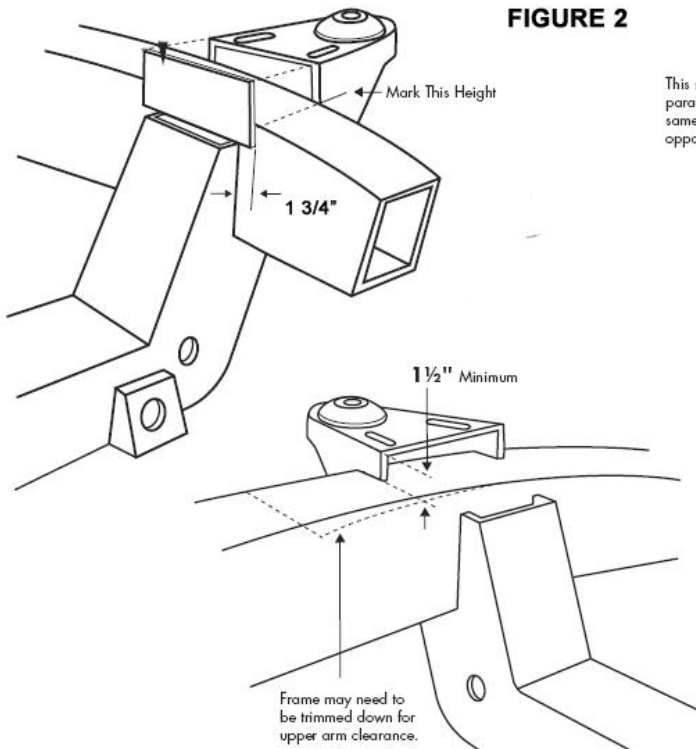
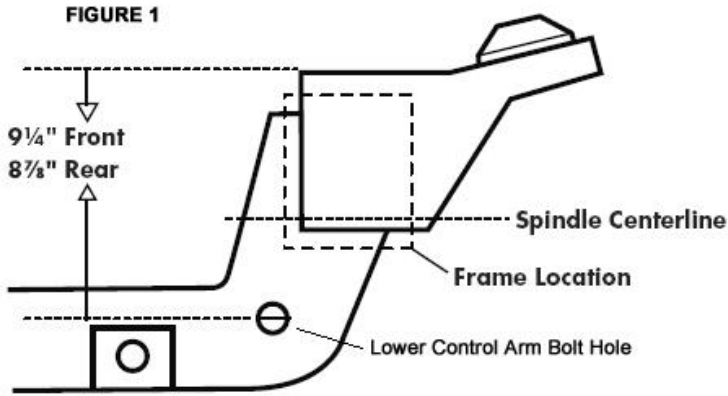

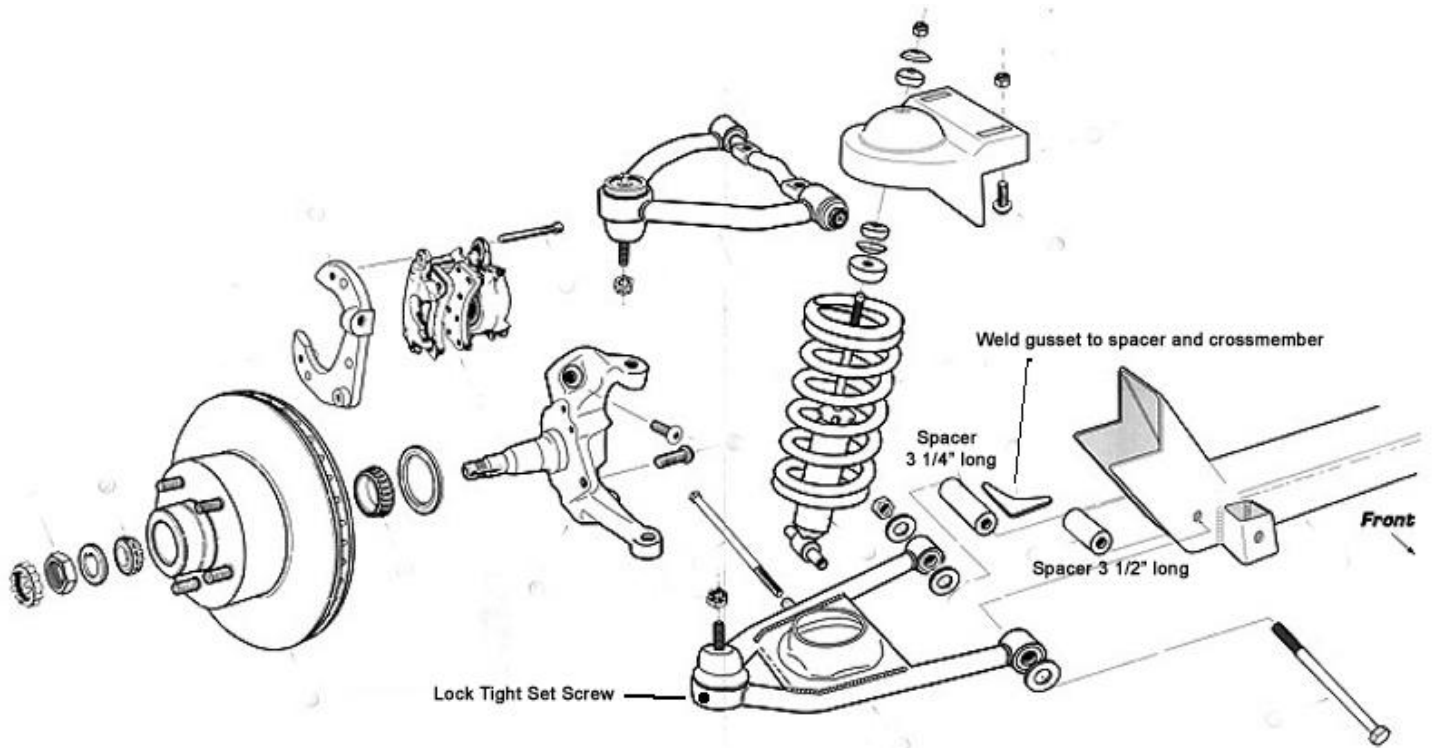

Thank You for buying Top-Quality, Made in America Parts from Full Tilt Street Rods, Inc. 970-255-8890

Visit us online at www.fulltiltstreetrods.com